

Champ®



AIR COMPRESSOR MODEL NO: CHAMP

PART NO: 2225215 (230V) & 2225220 (110V/32A)

OPERATION & MAINTENANCE INSTRUCTIONS

CE

ORIGINAL INSTRUCTIONS

DL0524 - Rev 7

INTRODUCTION

Thank you for purchasing this CLARKE Air Compressor.

Before attempting to operate the machine, it is essential that you read this manual thoroughly and carefully follow all instructions given. In doing so you will ensure the safety of yourself and that of others around you, and you can also look forward to the product giving you long and satisfactory service.

GUARANTEE

This CLARKE product is guaranteed against faulty manufacture for a period of 12 months from the date of purchase. Please keep your receipt as proof of purchase.

This guarantee is invalid if the product is found to have been abused or tampered with in any way, or not used for the purpose for which it was intended.

Faulty goods should be returned to their place of purchase, no product can be returned to us without prior permission.

This guarantee does not effect your statutory rights.

ENVIRONMENTAL RECYCLING POLICY



Through purchase of this product, the customer is taking on the obligation to deal with the WEEE in accordance with the WEEE regulations in relation to the treatment, recycling & recovery and environmentally sound disposal of the WEEE.

In effect, this means that this product must not be disposed of with general household waste. It must be disposed of according to the laws governing Waste Electrical and Electronic Equipment (WEEE) at a recognised disposal facility.

If disposing of this product or any damaged components, do not dispose of with general waste. This product contains valuable raw materials. Metal products should be taken to your local civic amenity site for recycling of metal products.

GENERAL SAFETY WARNINGS



WARNING: WHEN USING ELECTRICAL TOOLS, BASIC SAFETY PRECAUTIONS SHOULD ALWAYS BE FOLLOWED TO REDUCE THE RISK OF FIRE, ELECTRIC SHOCK AND PERSONAL INJURY

WARNING: READ ALL THESE INSTRUCTIONS BEFORE ATTEMPTING TO OPERATE THIS PRODUCT AND KEEP THESE INSTRUCTIONS IN A SAFE PLACE.

WORK AREA

1. **Keep the work area clean and well lit.** Floors should always be kept clear. Cluttered or dark areas invite accidents.
2. **Keep children and bystanders away while operating a power tool.** Distractions can cause loss of control.
3. The compressor should only be used in areas with adequate ventilation and should not be exposed to heat or used near flammable substances

PERSONAL SAFETY

1. **ALWAYS** stay alert, watch what you are doing and use common sense when operating the compressor. Do not use the compressor while you are tired or under the influence of medication, drugs or alcohol. A moment of inattention can result in personal injury.
2. **ALWAYS** use eye protection when operating compressed air equipment, and ensure that others in the work area are protected from flying particles from the front and from the side.
3. **ALWAYS** protect yourself against electric shock. Never operate the compressor in wet or damp locations.
4. **NEVER** over-reach. Keep your proper footing and balance at all times to enable better control of the compressor in unexpected situations.
5. **NEVER** attempt any complex repairs yourself. If you have a technical problem contact your local Clarke dealer.
6. **ALWAYS** store the compressor out of reach of children.
7. **ALWAYS** protect your hearing. Ear protection should be worn when operating this compressor and it's associated power tools.
8. **NEVER** direct the air stream at people or animals, as injury may result. Compressed air can cause soft tissue damage and propel dirt and other particles at high speed.

9. **NEVER** insert your fingers or other objects inside the motor housing. Never operate the compressor without the cover in place.
10. **NEVER** touch hot surfaces. During operation, the motor, connections, compressor body, cylinder head and tubes may get hot. Do not touch these until the compressor has cooled down.

GENERAL MACHINE USE AND CARE

1. Prior to use, all operators should become familiar with the instructions in this booklet especially the ON/OFF switch for emergency stopping.
2. **ALWAYS** maintain the compressor with care and keep it clean for best / safest performance.
3. **NEVER** use this compressor if any part is damaged. Have it inspected and repaired by your dealer.
4. **NEVER** attempt to modify the air compressor, tank, fittings or attachments in any way. Doing so will invalidate the guarantee and could result in personal injury.
5. **NEVER** abuse the power cable. Never pull on the cable when removing the plug from the socket, or lift the compressor by the power cable.
6. **ONLY** use extension leads that are of an appropriate power rating and suitable for the work environment. Extension leads must have an earth connection. Inspect the extension lead regularly and replace if damaged.
7. **ONLY USE RECOMMENDED PARTS:** To avoid the risk of bursting, only hoses with a rated pressure of 10 bar, or more should be used. Never attempt to repair damaged hoses.
8. **NEVER** abuse the compressor by standing on it.

AIRLINE HOSES

1. **ALWAYS** ensure that equipment or power tools used in conjunction with the compressor have a safe working pressure exceeding that of the machine.
2. **ALWAYS** keep the air hose away from any attached power tools and ensure that the operator is not restricted by the length of the hose.
3. **ALWAYS** take care when a long air hose is required in the work area as it presents a trip hazard. Coil the hose away as soon as the job is finished.
4. **ALWAYS** avoid kinking or trapping the air hose. Always replace faulty hoses and never attempt a repair if a leak is detected.
5. **NEVER** abuse hoses or connectors. NEVER carry an air tool by the hose, or yank it to disconnect from the air supply. Keep hoses away from heat, oil and sharp edges. Check hoses for leaks or worn condition before use and ensure that all connections are secure.

6. **ALWAYS** ensure that the air supply is turned off at the machine outlet and any air pressure vented from within the compressor and any attached equipment when disconnecting air hoses or other equipment.

AIR COMPRESSOR SAFETY INSTRUCTIONS

1. **ONLY USE WITHIN THE RECOMMENDED OPERATING TEMPERATURE RANGE:** This compressor should only be used in an ambient temperature of between +5°C and +40°C (never at or below freezing temperatures).
2. **NEVER USE AN AIR COMPRESSOR WHICH APPEARS DEFECTIVE OR IS OPERATING ABNORMALLY:** If the compressor operates unusually or makes strange noises, switch off immediately and purge the air reservoir. Arrange repairs with your nearest Clarke dealer.
3. **BREATHING QUALITY AIR:** This compressor should not be used to supply breathing quality air.
4. **SAFETY VALVE:** Never remove or attempt to adjust the safety valve. The maximum pressure is factory set. Keep the safety valve free from paint and other accumulations.
5. **AVOID UNINTENTIONAL STARTING:** Do not move the compressor when it is connected to the mains power supply. When connecting the compressor to the power supply make sure the red button on top of the control box is in the **OFF** (down) position.
6. **BEFORE EACH USE CHECK THE COMPRESSOR AND HOSE FOR DAMAGED PARTS:** Never use the compressor if it has been damaged in any way. Have the compressor repaired by a qualified service engineer. Do not use the compressor if the On/Off switch does not operate correctly.
7. **KEEP THE MOTOR AIR VENTS CLEAR:** Keep the motor vents clear and free from dust. Wipe regularly to maintain an adequate supply of clean air. Avoid using in dusty conditions.
8. **OPERATE THE COMPRESSOR AT THE CORRECT VOLTAGE:** Make sure that the mains supply voltage is the same as the voltage shown on the label.
9. **ALWAYS** adjust the pressure regulator to the recommended setting for the particular spray gun or air tool being used.
10. When using the compressor for painting:
 - Do not work in enclosed areas or near naked flames.
 - Ensure that the area in which you are working has good ventilation.
 - Protect your nose and mouth with a suitable face mask.
 - Always check the safety data sheets for substances being sprayed & ensure manufacturer's instructions are followed.

11. **DO NOT USE THIS COMPRESSOR TO INFLATE SMALL, LOW-PRESSURE OBJECTS:** Items such as children's toys or footballs can explode if over-inflated.
12. **NEVER STOP THE COMPRESSOR BY REMOVING THE PLUG OR SWITCHING OFF AT THE MAINS SUPPLY:** Always use the On/Off switch on the compressor.

SAFETY SYMBOLS

| | |
|---|---|
|  | <p>Read this instruction booklet carefully before positioning, operating or adjusting the compressor.</p> |
|  LWA  | <p>This compressor produces a high sound level during operation. Ear protection should be worn.</p> |
|  | <p>This compressor contains surfaces which may get hot during operation. Never operate with the motor housing removed.</p> |
|  | <p>Risk of accidental start-up. The compressor could start automatically in the event of a power cut and subsequent reset. Do not carry the compressor while it is connected to the power source, or when the receiver is filled with compressed air.</p> |
|  | <p>Risk of electric shock. The compressor must be disconnected from the mains supply before removing any covers. Do not use in a damp environment.</p> |
|  | <p>This compressor should always be started or stopped by means of the start/stop button located on the control box. This reduces the risk of accidental start-up.</p> |
|  | <p>this compressor should never be stopped suddenly by unplugging from the mains supply. this increases the risk of accidental start-up. never abuse the power cable</p> |

ELECTRICAL CONNECTIONS



WARNING: READ THESE ELECTRICAL SAFETY INSTRUCTIONS THOROUGHLY BEFORE CONNECTING THE PRODUCT TO THE MAINS SUPPLY.

Before switching the product on, make sure that the voltage of your electricity supply is the same as that indicated on the rating plate. Connecting it to any other power source may cause damage.

CHAMP/230V

Connect the mains lead to a standard, 230 Volt (50Hz) electrical supply through an approved 13 amp BS 1363 plug, or a suitably fused isolator switch.

If the plug has to be changed because it is not suitable for your socket, or because of damage, it must be removed and a replacement fitted, following the wiring instructions shown below. The old plug must be discarded safely, as insertion into a power socket could cause an electrical hazard.



WARNING: THE WIRES IN THE POWER CABLE OF THIS PRODUCT ARE COLOURED IN ACCORDANCE WITH THE FOLLOWING CODE:
BLUE = NEUTRAL BROWN = LIVE YELLOW AND GREEN = EARTH

- The BLUE wire must be connected to the terminal which is marked N or coloured black.
- The BROWN wire must be connected to the terminal which is marked L or coloured red.
- The YELLOW AND GREEN wire must be connected to the terminal which is marked E or  or coloured green.

Plug must be BS1363/A approved.

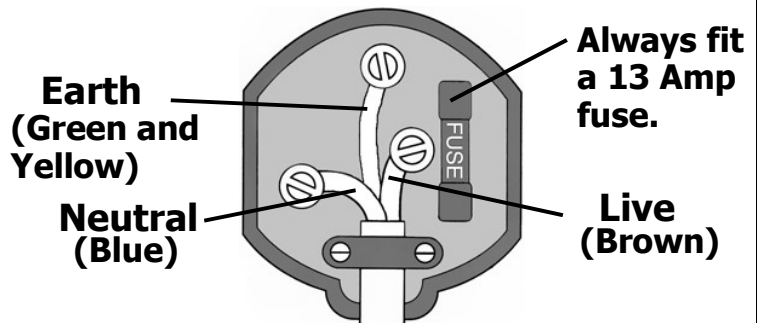

Ensure that the outer sheath of the cable is firmly held by the clamp

We strongly recommend that this machine is connected to the mains supply through a Residual Current Device (RCD).

If you are not sure, consult a qualified electrician. **DO NOT** try to do any repairs.

CHAMP: 110V/32A

Connect the mains lead to a suitable 110V (50Hz) electrical supply through an approved 32A plug or a suitably fused isolator switch.

If using a portable 110V transformer, make sure it has a 32A rated capacity sufficient to take the load of the air compressor.

If the plug has to be changed due to damage, a replacement should be fitted, following the wiring instructions shown below. The old plug must be disposed of as insertion into a 110v socket could cause an electrical hazard.



WARNING: THE WIRES IN THE POWER CABLE OF THIS PRODUCT ARE COLOURED IN ACCORDANCE WITH THE FOLLOWING CODE:
BLUE = NEUTRAL BROWN = LIVE YELLOW = EARTH

If the colours of the wires in the power cable of this product do not correspond with the markings on the terminals of your plug, proceed as follows.

- The **Blue** wire must be connected to the terminal which is marked **N** or **Neutral**.
- The **Brown** wire must be connected to the terminal which is marked **L** or **Live**.
- The **Yellow** wire must be connected to the terminal which is marked **E** or **Earth**.

If in any doubt, consult a qualified electrician. **DO NOT** attempt any repairs yourself.

Plug must be BS60309 approved.

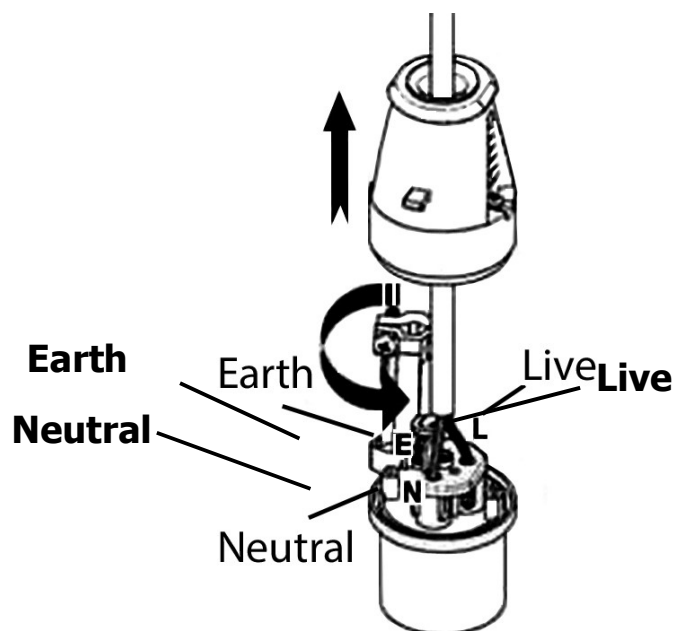

OVERVIEW

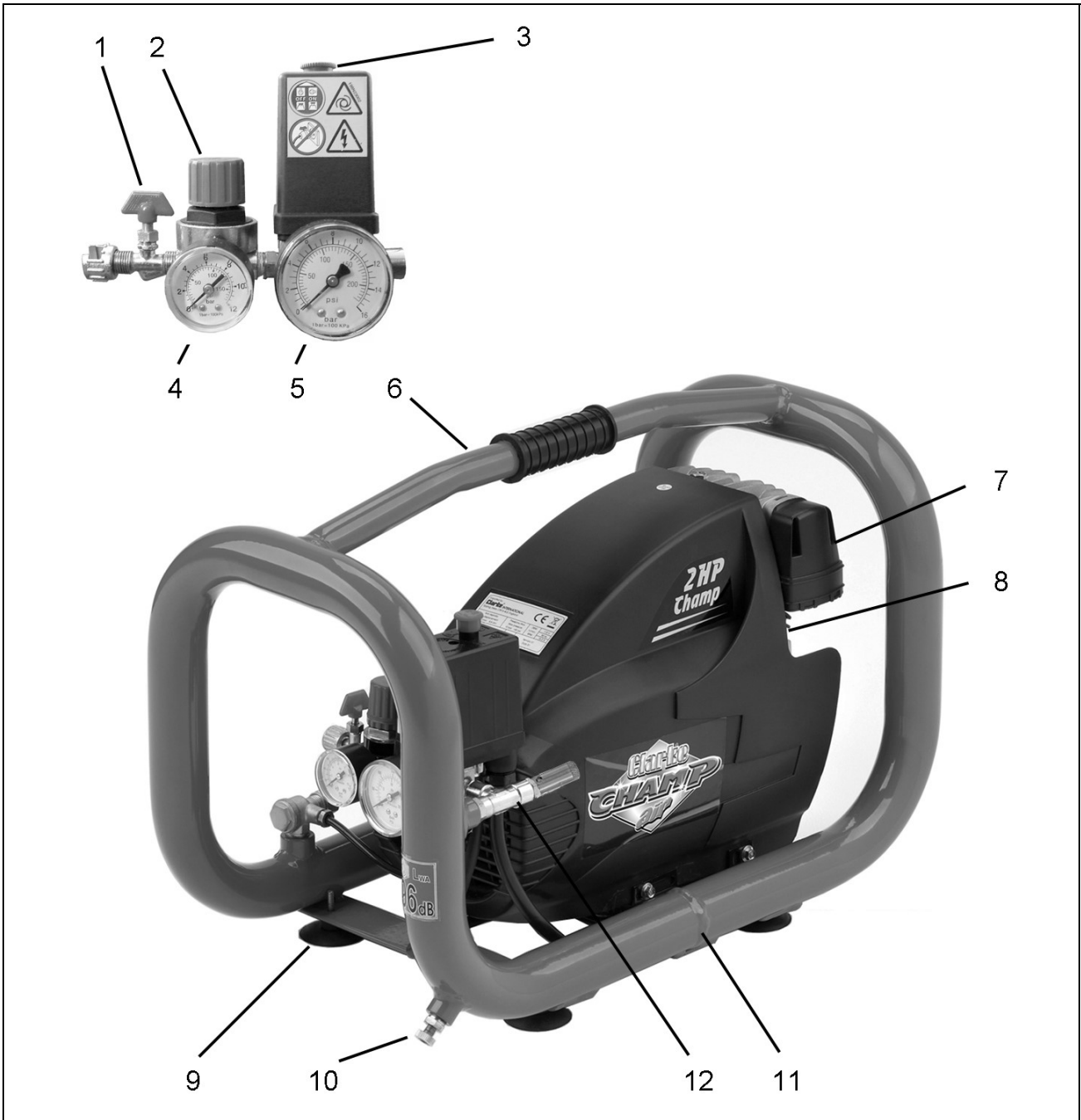

| | |
|---|---------------------------|
| 1 | Shut-off valve |
| 2 | Output pressure regulator |
| 3 | On/Off switch |
| 4 | Outlet pressure gauge |
| 5 | Reservoir |
| 6 | Handle |
| 7 | Air filter |

| | |
|----|--------------------------|
| 8 | Oil filler/ dipstick |
| 9 | Anti-vibration feet |
| 10 | Drain valve |
| 11 | Compressed air reservoir |
| 12 | Pressure safety valve |
| 13 | Pressure control switch |
| | |

PREPARATION FOR USE



WARNING: BEFORE USING THE COMPRESSOR, MAKE SURE THAT YOU HAVE READ AND UNDERSTOOD THE SAFETY INSTRUCTIONS.

UNPACKING

Take care when lifting the compressor from the packaging and obtain assistance if necessary to avoid personal injury or damage to the machine. Always use the handle and frame.



CAUTION: NEVER TAKE THE WEIGHT OF THE COMPRESSOR BY HOLDING THE PRESSURE CONTROL SWITCH OR OTHER ATTACHED PARTS.

After removing the compressor from its packaging, check that it has not been damaged in transit. Report any damage immediately to the dealer where the item was purchased.

POSITIONING THE COMPRESSOR

This compressor should be positioned on a stable, flat surface.

NOTE: Note: the compressor should not be operated on a steep slope or floor angle of greater than 15°.

If the compressor is placed on a shelf or raised off the ground, it should be secured appropriately to prevent it from falling off during use.

Do not cover the compressor. Always position it with good all-round air ventilation.

MOVING THE COMPRESSOR

When moving the compressor;

- Always use the handle/frame.
- Do not lift by (or place a strain on) the airline fittings or hoses.
- Take care to avoid damaging the valves or fittings.
- Always ensure it is switched off and disconnected from the power supply.

CONNECTION AND START UP

Before connecting your compressor to the mains supply, check the following:-

- The supply voltage must be 110V (Champ 110 V - Part No; 2225220) or 230V (Champ 230 V - Part No; 2225215).
- The ON/OFF switch is in the OFF (depressed) position.
- The pressure regulator should be set at its lowest setting, i.e. turned fully anticlockwise. (- & + arrows are shown on the knob).
- If the compressor has not been used recently, open the drain valve shown to drain any condensate which may have accumulated. When clear, close the valve, finger tight.

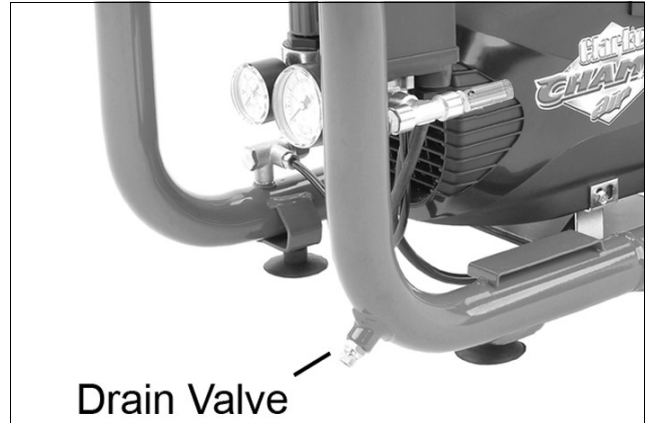

IMPORTANT: If the receiver is under pressure, keep your hands well away from the air being expelled. Remember, compressed air is DANGEROUS.



WARNING: BEFORE CONNECTING ANY AIR TOOL, MAKE SURE YOU HAVE READ AND FULLY UNDERSTOOD THE MANUFACTURER'S INSTRUCTION BOOKLET FOR THE AIR TOOL BEING USED. ALSO ENSURE THAT THE AIR TOOL IS COMPATIBLE WITH THE COMPRESSOR AND HOSE SPECIFICATIONS. IF THE PRESSURE RATING OF THE TOOL IS LESS THAN 10 BAR, THE PRESSURE REGULATOR MUST BE USED TO ADJUST THE OUTPUT PRESSURE.

1. Connect a suitable air hose to the compressor outlet and the other end to the equipment to be used.
2. Attach the air hose to the air outlet using the hose nut as shown.
3. Ensure that the drain valve is closed finger tight as above.
4. Ensure the ON/OFF switch is in the OFF position, i.e. pushed down, then plug in the machine and switch ON at the mains supply.



CHECKING THE OIL

1. Remove dipstick as shown and check the level of oil is between the MAX and MIN marks as shown below. If not, top up to the correct level with Clarke SAE40 compressor oil available from your Clarke dealer.
2. After the first 5 working hours, replace the oil as described under MAINTENANCE on page 15.



OPERATING INSTRUCTIONS

STARTING THE COMPRESSOR

1. Pull the ON/OFF switch shown in Fig 5, upwards to start the compressor. The motor should start immediately and run while the reservoir is being pressurised.
 2. When starting the compressor for the first time and before connecting it to the airline equipment, leave it running for about 10 minutes to permit a good distribution of lubricating oil.
 3. Check the operation of the safety valve under pressure on a daily basis by twisting the end of the valve as shown above. Air should be released when the knurled part is twisted.
- If the valve does not operate as described, or is stuck, it must be replaced by your Clarke dealer before the compressor is used.

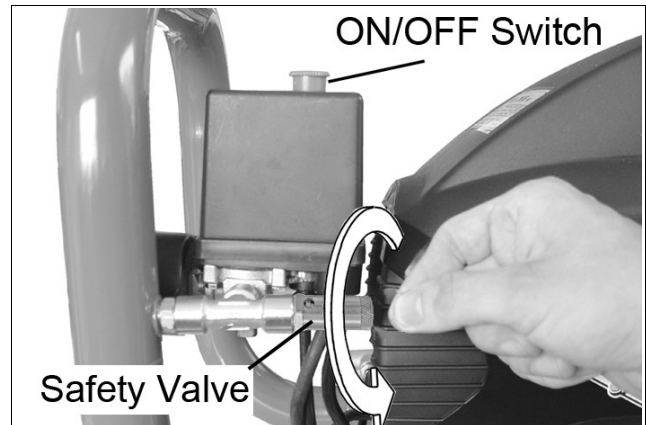

WARNING: NEVER REMOVE OR ATTEMPT TO ADJUST THE SAFETY VALVE.

- Observe that the compressor stops automatically when the maximum pressure of 10 bar is reached. The pressure is indicated on the reservoir pressure gauge shown below.

WORKING PRESSURE ADJUSTMENT

Different air tools which can be powered by the compressor will require different operating pressures to work efficiently.

1. Adjust the air pressure delivered using the pressure regulator.
 2. Turn the pressure regulator knob clockwise to increase pressure & anti-clockwise to decrease it.
- The pressure setting will be displayed by the outlet pressure gauge shown.

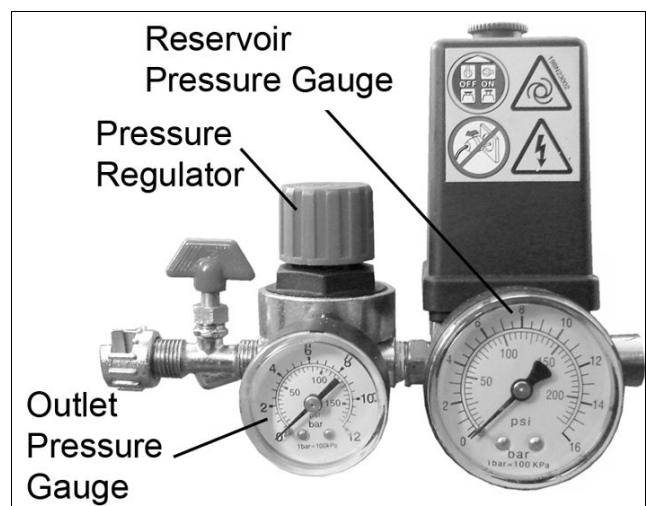

- Use the regulator locking ring to set the pressure.

NORMAL RUNNING

The compressor is fitted with a combined ON/OFF pressure control switch whose cut-in and cut-out pressures are factory set.

When the reservoir pressure falls below the minimum threshold setting, (about 2-bar lower than the maximum pressure) the compressor will re-start and will cut out when the maximum reservoir pressure is achieved.

Note: If the machine pumps continuously without intermittently switching on and off, the compressor is too small for the demand of the application/tool being used and damage could result. Consult your Clarke dealer.

OVERLOAD CUT OFF SWITCH

Both the 230v and 110v models have a built in overload cut off switch. This will activate if the current reaches 16amp.

If the overload cut off switch is activated, allow the machine to cool down before trying to restart.

SHUTTING DOWN AND STORAGE

Press the red ON/OFF switch to shut off the compressor.

Never stop the compressor by unplugging it from the power supply. It should be turned off as above.

After use, set the outlet pressure back to zero.

Trigger all equipment (tools, spraygun etc) to release any air pressure from the air hose before disconnecting the hose from the compressor.

Before transporting or storing the compressor, release all air pressure from the reservoir by opening the drain valve.

- It may be desirable to place a container beneath the compressor to catch any condensate.

Avoid storing the compressor in an environment where the temperature is likely to drop to or below freezing.

MAINTENANCE



WARNING: ALWAYS VENT THE AIR RECEIVER BEFORE CARRYING OUT ANY ADJUSTMENTS, SERVICING OR MAINTENANCE. NEVER UNSCREW A CONNECTION WHILST THE AIR RECEIVER IS UNDER PRESSURE. ALWAYS ENSURE THE RECEIVER HAS BEEN VENTED.

DAILY / WEEKLY / BEFORE USE

1. Drain any condensate by opening the drain valve fitted to the receiver. As soon as air starts to flow out, close the drain cock.
2. Inspect the compressor for damaged parts or for any loose screws or bolts.
3. Check the oil level is between the MAX & MIN marks on the dipstick & top up if necessary. (Use Clarke SAE40 compressor oil). Ensure the oil does not drop below the minimum level to avoid damage to the machine.

PERIODICALLY

1. Check and clean, if necessary, the sponge air inlet filter element shown. The filter may be removed from the plastic cover and gently washed in warm soapy water. Rinse and allow to dry thoroughly before re-fitting.
 - This should be done more frequently if the compressor operates in a very dusty area.)
2. Keep the cooling fins clear of dust if the machine is being used in a dirty workplace.



CAUTION: NEVER OPERATE THE COMPRESSOR WITHOUT THE SPONGE FILTER FITTED, AS FOREIGN MATTER COULD SERIOUSLY DAMAGE THE INTERNAL COMPONENTS. IF DAMAGED, THE FILTER SHOULD BE REPLACED.

6 MONTHLY/500 HOURS

If the oil has become contaminated it should be replaced as follows;

1. Remove the dipstick and unscrew the drain plug from the crankcase cover and drain the oil into a container.

NOTE: This operation is best performed when the machine is warm so as to encourage the oil to drain easily.

2. Replace the drain plug and re-fill with fresh oil up to the MAX level on the dipstick using Clarke SAE40 compressor oil.

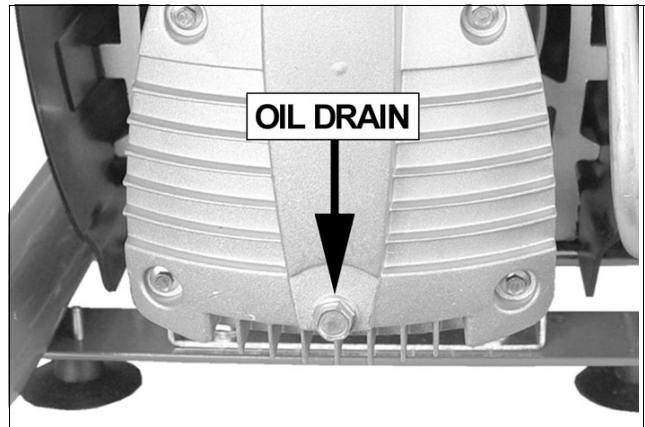

CAUTION: PROLONGED EXPOSURE TO USED OIL IS DANGEROUS, ALWAYS WASH YOUR HANDS THOROUGHLY AFTER HANDLING USED OIL.

RECOMMENDED OILS

Any compressor oil can be used which is suitable for use at room temperatures from +5°C to + 40°C.

Clarke SAE40 Compressor Oil (1 litre) is available from your Clarke dealer (part no 3050810). See the Clarke catalogue for other consumables.

ENVIRONMENTAL PROTECTION

One of the most damaging sources of environmental pollution is oil. Do not throw away used oil with domestic refuse or flush down a sink or drain. Collect old oil in a leak-proof container and take it to your local waste disposal site.

EVERY 2 YEARS

Check the non-return valve shown and if necessary, replace the gasket (O-ring).

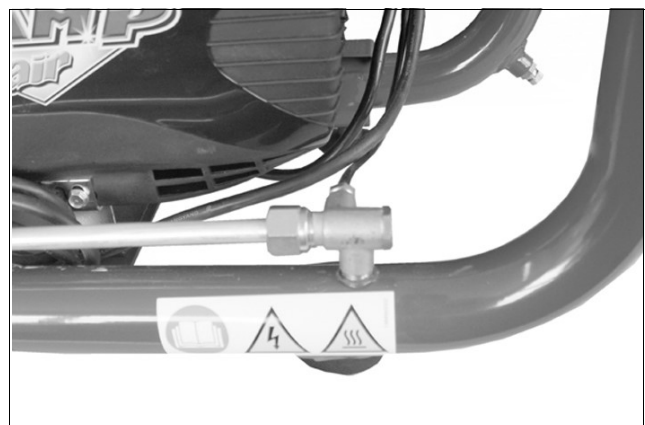

IMPORTANT: The use of parts other than Clarke replacement parts may result in safety hazards, decreased tool performance and will invalidate your warranty.

NOTE: Your Clarke compressor has been designed to give long and trouble free service. If, however, having followed the instructions in this booklet carefully, you encounter problems, take the unit to your local Clarke dealer.

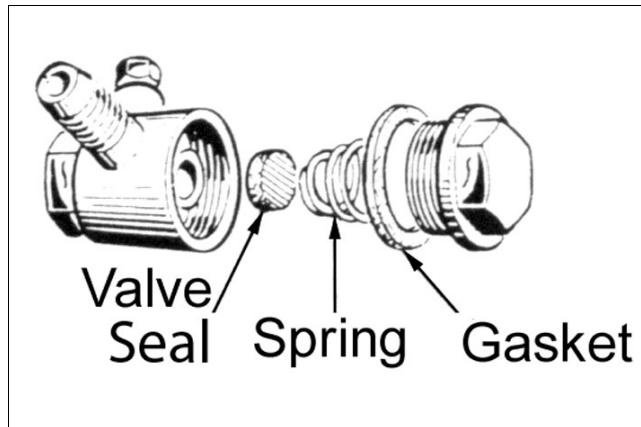

FAULTFINDING

| SYMPTOM | PROBLEM | SOLUTION |
|--|--|---|
| Pressure drop in the receiver. | Air leaks at connections. | Run the compressor to create maximum pressure. Switch it off and brush a soapy water solution onto all connections. Look carefully for air bubbles being forced out. Tighten any connections where bubbles are seen. If problem persists contact your dealer. |
| Compressor stops and will not start again. | Bad electrical connections. Blown fuse. Overload cut-out switch has tripped. | Check connections. Clean and tighten as necessary. Renew/replace fuse. Switch off machine and wait 5 minutes before pressing reset button. |
| Compressor fails to reach the set pressure and overheats easily. | Compressor head gasket failed or valve damaged. | Stop the compressor and contact your dealer. |
| Compressor does not start. | Air reservoir already pressurised. | Open drain valve and expel some air. Compressor should re-start when the reservoir pressure trips the pressure control switch at app. 95 psi. |
| Air found leaking from the pressure switch valve when the compressor is not running. | Faulty non-return valve. | Vent the receiver totally of air. Remove valve end plug, carefully clean the valve end seat and gasket, then re-assemble. See Fig 11. |
| Pressure switch valve leaks after the compressor has been running for more than about a minute | Failure of the empty-start valve in pressure control switch. | Replace the pressure control switch. |
| Air pressure cannot be adjusted at the regulator | Broken diaphragm inside the regulator body. | Replace regulator. |

| | | |
|---|---|---|
| Compressor keeps running after the maximum pressure is reached, causing the safety valve to activate. | Incorrect operation of the pressure control switch. | Contact your Clarke dealer |
| Compressor making undue mechanical noise. | Compressor is damaged and needs overhaul | Stop the compressor and contact your Clarke dealer. |
| Compressor will not run. | Motor winding burnt out. | Contact your Clarke dealer |

In the event that any of the above situations arise, requiring the dismantling and overhaul of the compressor, contact your Clarke International Service Department on 020-8988-7400.

SPECIFICATION

| Model | 110V | 230V |
|------------------------------|--------------------------|-------------|
| Part No | 2225220 | 2225215 |
| Power supply | 110V@50Hz | 230V@50Hz |
| Fuse rating | 32A Transformer | 13 amps |
| Dimensions (L x W x H) | 540 x 300 x 388 | |
| Weight | 21.5 kg | |
| Air receiver capacity | 2.4 litres | |
| Duty cycle | S1 (continuous) | |
| Max Air pressure | 10 Bar/145 psi | |
| Max flow rate | 217L/min (7.6 cu.ft/min) | |
| Operating temperature | +5°+40°C | |
| Sound power level | 95 dB LwA | |
| Guaranteed sound power level | 96 dB LwA | |

Please note that the specifications contained herein, are correct at the time of going to print. However, Clarke International reserve the right to change specifications at any time without prior notice.

PARTS LIST & DIAGRAM - COMPRESSOR

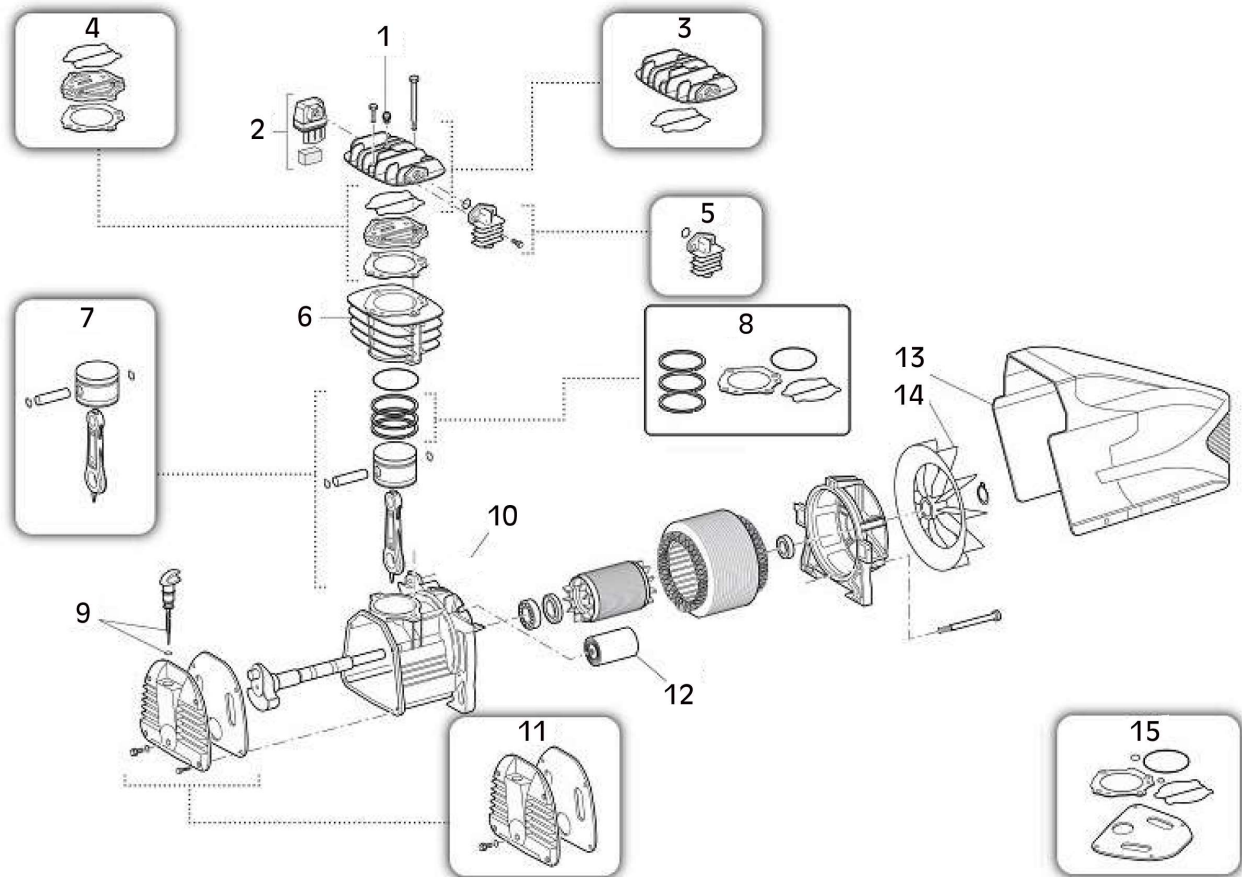

| No | Description |
|----|-------------------|
| 1 | Safety Valve |
| 2 | Air Filter |
| 3 | Piston Head Cover |
| 4 | Valve Plate |
| 5 | After Cooler |
| 6 | Piston Casing |
| 7 | Piston |
| 8 | Piston Rings |

| No | Description |
|----|--------------------|
| 9 | Oil Cap/Dipstick |
| 10 | Piston Block |
| 11 | Cover Plate |
| 12 | Capacitor |
| 13 | Compressor Housing |
| 14 | Fan |
| 15 | Gasket Seals |
| | |

PARTS LIST & DIAGRAM - ANCILLARY ITEMS

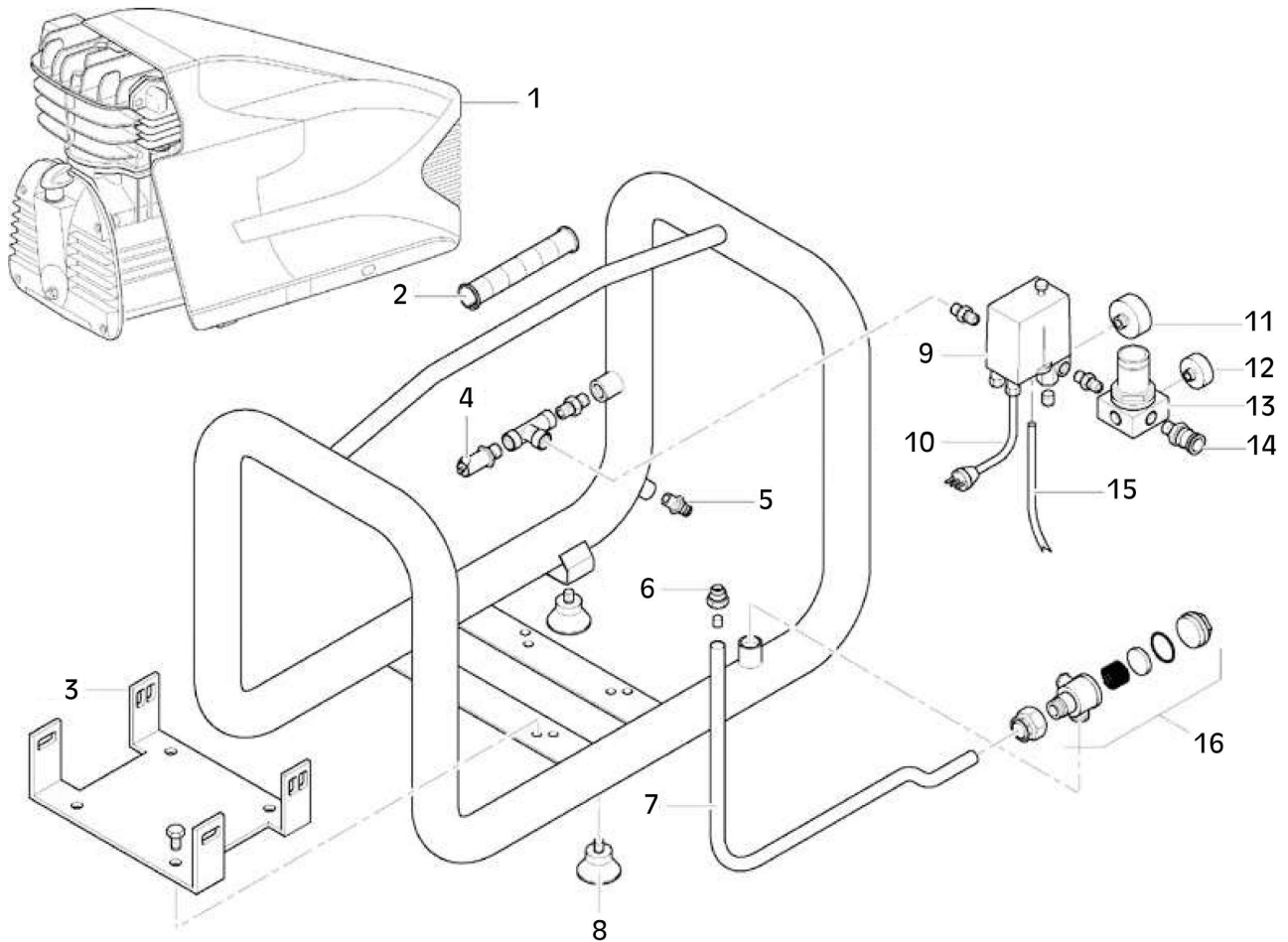

| No | Description |
|----|------------------------|
| 1 | Compressor Housing |
| 2 | Handle Grip |
| 3 | Support Bracket |
| 4 | Safety Valve |
| 5 | Condensation Drain Tap |
| 6 | Locknut |
| 7 | Delivery Tube |
| 8 | Foot |

| No | Description |
|----|--------------------------------------|
| 9 | Pressure Switch |
| 10 | Power Cable |
| 11 | Reservoir Pressure Gauge 0-300psi |
| 12 | Outlet Pressure Gauge 0-180psi |
| 13 | Pressure Reducer |
| 14 | Shut Off Valve & Air Outlet |
| 15 | Connecting Tube |
| 16 | Check Valve |

DECLARATION OF CONFORMITY



Clarke[®]
INTERNATIONAL

Hemnall Street, Epping, Essex CM16 4LG

DECLARATION OF CONFORMITY

This is an important document and should be retained.

We, Clarke International, as the authorised representative of the manufacturer, declare that the following product(s) comply with the directive(s) and standard(s) listed below.

Product Description: Air Compressor
Model number(s): Champ 230V, Champ 110V (2HP, 1PH,)
Serial / batch Number: 2225215, 2225220
Notified Body: N/A.

Technical Documentation Holder: A.R. Pond
Clarke International
2a Shrubland Road
London E10,7RB
UK

Conformity Assessment Procedure: to 2000/14/EC Annex VI
Manufacturer: European Supplier
Noise Related Value: 1.5 kW
Measured Sound Power Level: 95 dB
Guaranteed Sound Power Level: 97 dB

DECLARATION OF CONFORMITY



Clarke[®]
INTERNATIONAL

Hemnall Street, Epping, Essex CM16 4LG

DECLARATION OF CONFORMITY

This is an important document and should be retained.

Directive(s):

2006/42/EC *Machinery Directive.*
2000/14/EC *Noise Emissions Directive, (amended by 2005/88/EC).*
2014/30/EU *Electromagnetic Compatibility Directive.*
2011/65/EU *Restriction of Hazardous substances.*

Standard (s):

EN 1012-1, EN 60204-1, EN 61000-6-3, EN 61000-6-4.

The technical documentation required to demonstrate that the product(s) meet(s) the requirement(s) of the aforementioned directive(s) has been compiled and is available for inspection by the relevant enforcement authorities.

The CE mark was first applied in: 2018

Signed:

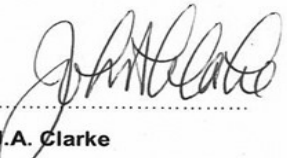
.....
J.A. Clarke
Director

Date of Issue:

15/06/2018

Place of issue:

Clarke International
Hemnall Street
Epping
Essex, CM16 4LG
England

A SELECTION FROM THE VAST RANGE OF

Clarke®

QUALITY PRODUCTS



AIR COMPRESSORS
From DIY to industrial, Plus air tools, spray guns and accessories.

GENERATORS
Prime duty or emergency standby for business, home and leisure.

POWER WASHERS
Hot and cold, electric and engine driven - we have what you need

WELDERS
Mig, Arc, Tig and Spot. From DIY to auto/industrial.

METALWORKING
Drills, grinders and saws for DIY and professional use.

WOODWORKING
Saws, sanders, lathes, mortisers and dust extraction.

HYDRAULICS
Cranes, body repair kits, transmission jacks for all types of workshop use.

WATER PUMPS
Submersible, electric and engine driven for DIY, agriculture and industry.

POWERTOOLS
Angle grinders, cordless drill sets, saws and sanders.

STARTERS/CHARGERS
All sizes for car and commercial use.



PARTS & SERVICE: 0208 988 7400

Parts Enquiries
Parts@clarkeinternational.com

Servicing & Technical Enquiries
Service@clarkeinternational.com

SALES: UK 01992 565333 or Export 00 44 (0)1992 565335

Clarke® INTERNATIONAL Hemnall Street, Epping, Essex CM16 4LG
www.clarkeinternational.com